

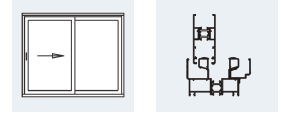

# Aluminium sliding – ALU CS bogie wheel



ALU CS 120kg H35 bogie wheel

3

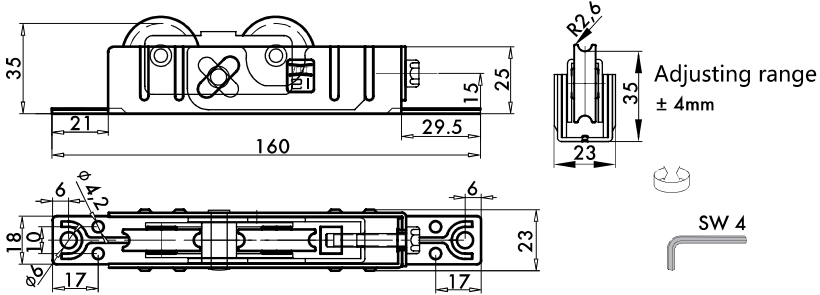

- Roller contact surface angle is 150°
- max. 120kg/pair

ALU CS 120kg H35 bogie wheel

4

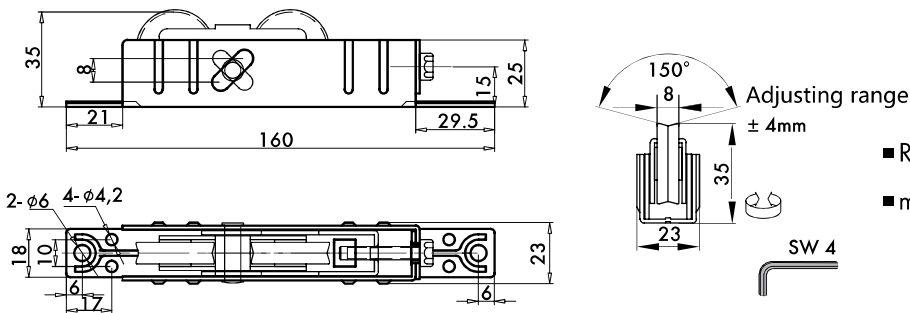

- Roller contact surface angle is 150°
- max. 120kg/pair

ALU CS 120kg H27 bogie wheel

5

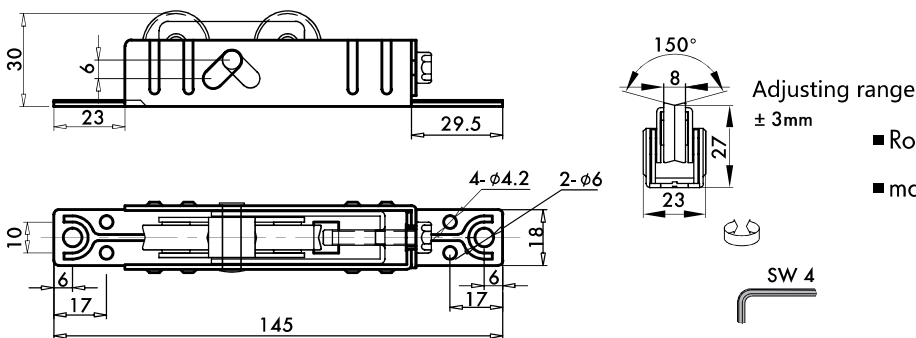

- Roller contact surface angle is 150°
- max. 120kg/pair

ALU CS 150kg bogie wheel

6

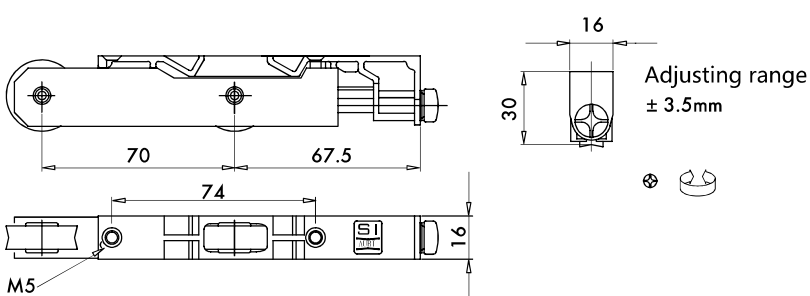

- Roller contact surface angle is 155°
- max. 150kg/pair

