

HS-PORTAL 200 LM

Lift and sliding hardware for aluminium doors
Hardware information for profile manufacturer

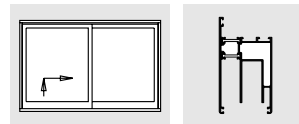

... with the following benefits:

- with integrated night vent
- profile cylinder accessories
- secure due to 4 locking points on the drive gear
- fixed wheels allow simple and easy assembly
- smooth operation

Size range

Sash width	(mm)	profile dependent max. 2485
Sash height (<i>Sliding sash</i>)	(mm)	profile dependent max. 2675
Frame width	(mm)	with Scheme A max. 5000
Frame height	(mm)	profile dependent
Sash weight	(kg)	max. 200
Backset (<i>Gear</i>)	(mm)	27,5
Handle position (<i>Window</i>)	(mm)	from top edge running rail 395
Handle position (<i>Door</i>)	(mm)	from top edge running rail 995

Contents

Size range.....	Page 1	Fitting detail(I).....	Page 6
Fittings layout.....	Page 2	Fitting detail(II).....	Page 7
Parts list.....	Page 3	Scheme Options.....	Page 8
Profile dependent measurements.....	Page 4	Specifics on scheme C.....	Page 9
Accessories.....	Page 5	Jigs.....	Page 10

Assembly instruction
HSgb7019

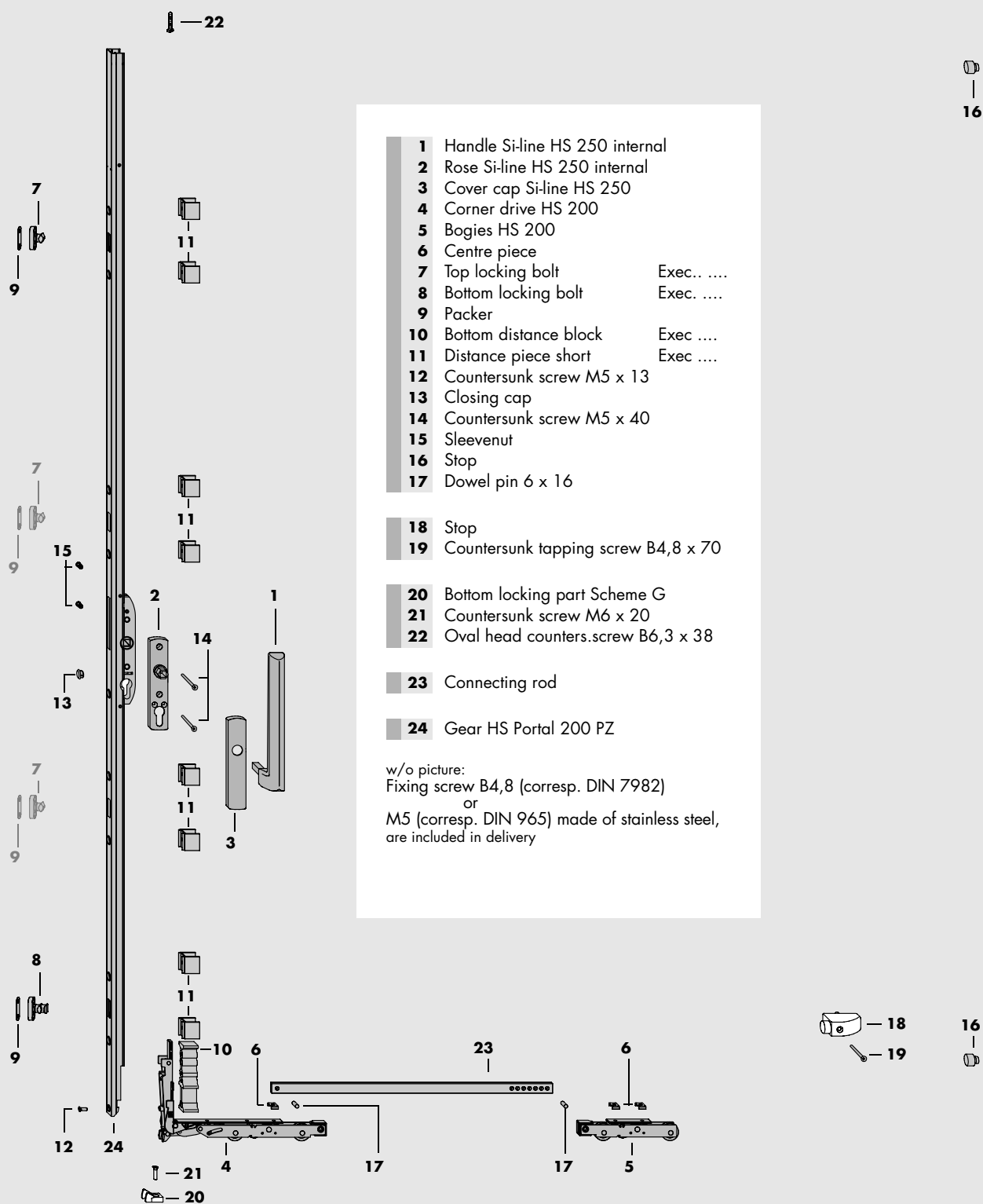

Flexible by optimized packing units

- Handle Si-line HS 250 internal (1) and Cover cap Si-line HS 250(3) available in white RAL 9016 – silver – si-brown
 - Basic parts (4 to 17) in Carton HS-Portal 200 LM (profile dependent)
 - Sash width dependent connecting rod size 150 to 335 (23)
- Sash height dependent Gear HS-Portal 300 PZ size 170, 220 and 260 (24)

Distance block(10) and Distance piece, short(11)

Cross section A-B

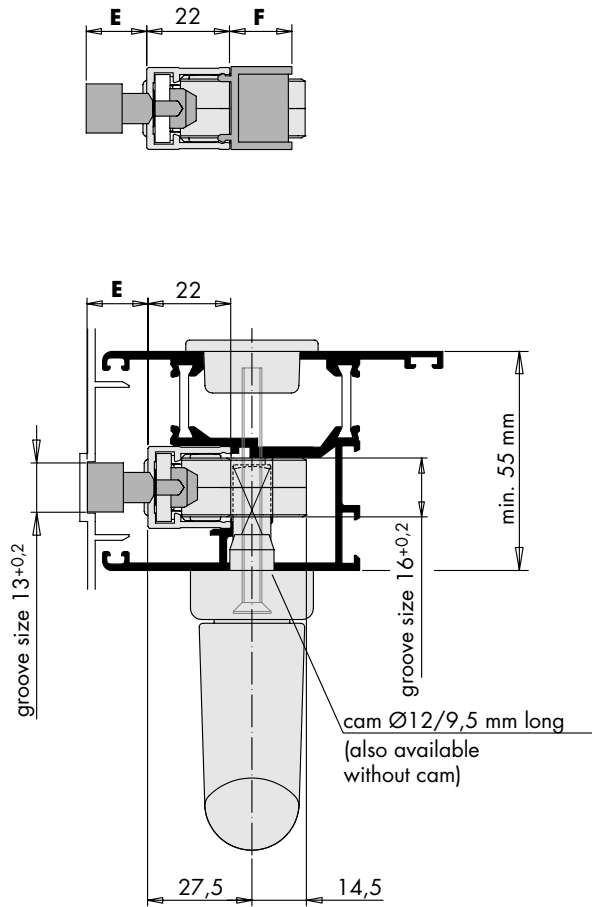

Cross section C-D

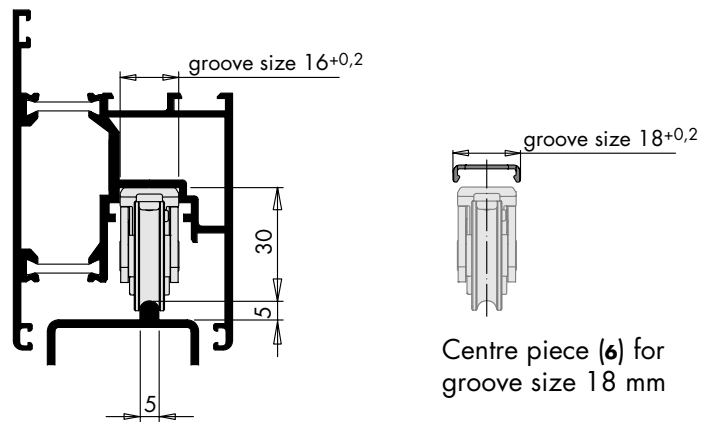

**Handle Si-line
HS 250 PZ A0156
internal and external
lockable**

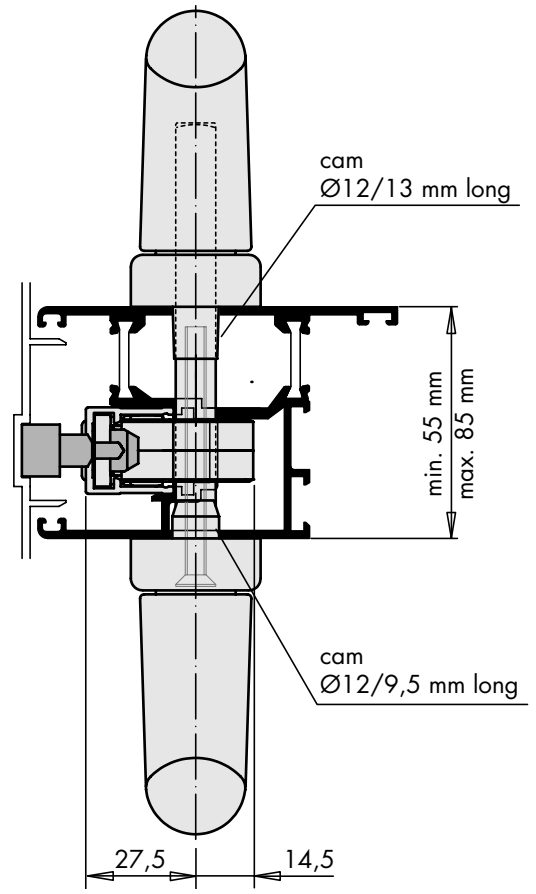
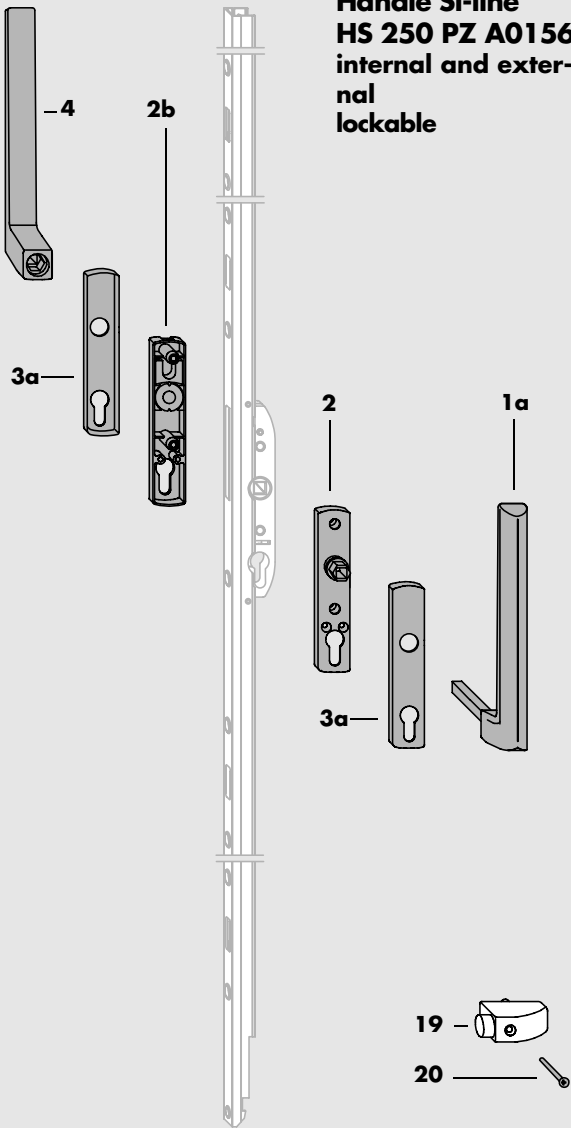

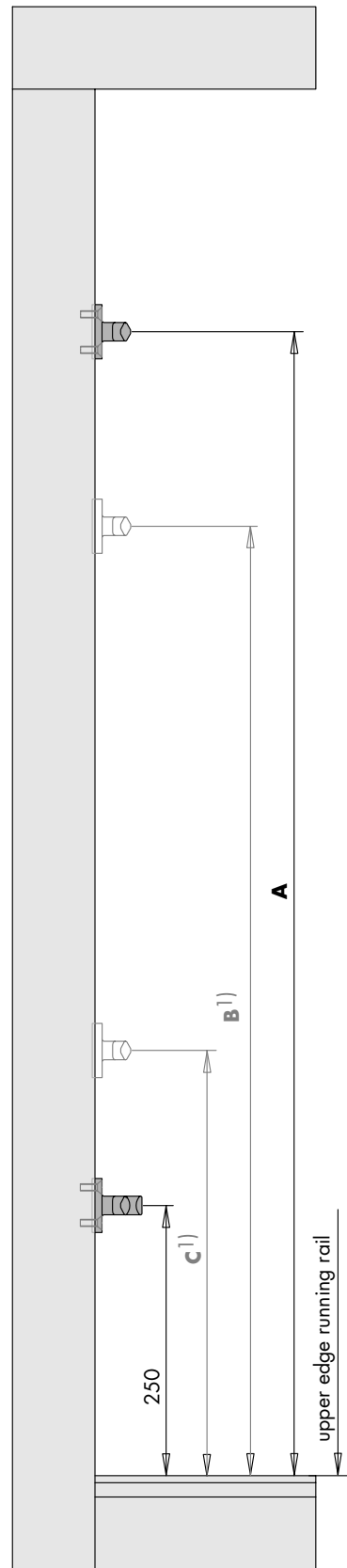

Sash cover plate (profile dependent)

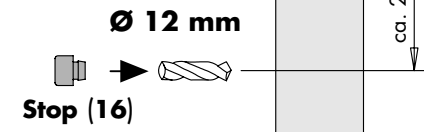
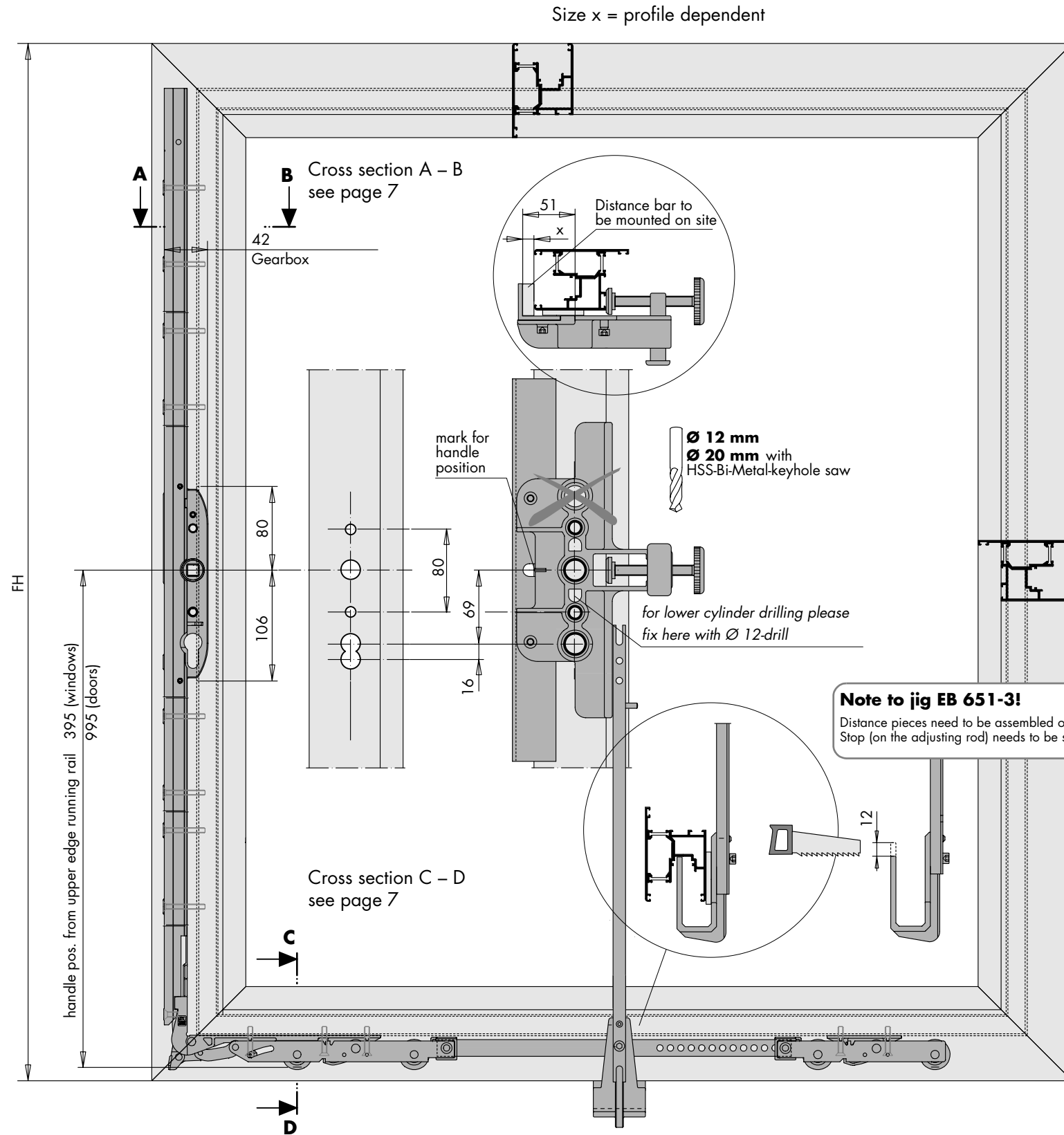
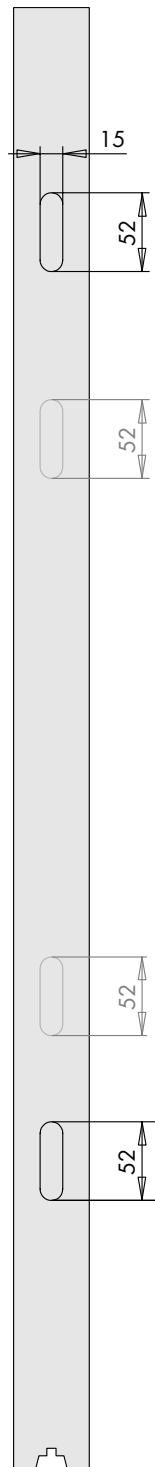

Note to jig EB 651-3!
Distance pieces need to be assembled on site
Stop (on the adjusting rod) needs to be shortened by 12 mm.

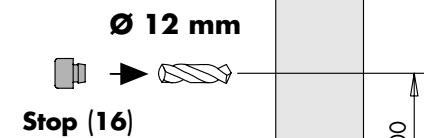

Gear	Size A	Size B ¹⁾	Size C ¹⁾	Sash height ²⁾
Gr. 170	1000	600	-	1175 - 1775
Gr. 220	1600	1200	750	1776 - 2275
Gr. 260	2200	1200	750	2276 - 2675

1) If requested 2 pcs top locking bolts (6) can be used as additional centre lock. The locking points on Gear HS-Portal 300 PZ (23) must be opened.

2) Small deviations possible (profile dependent)

HS-PORTAL 200 LM *Hardware information Scheme Options*

DIN left hand or **DIN right hand**

Scheme A



Scheme D

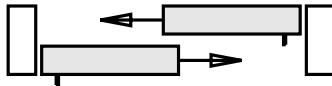

Scheme G

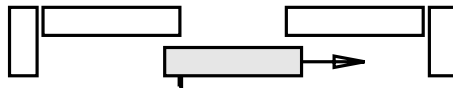

Scheme H

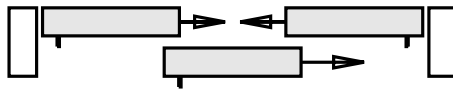

Scheme C



Scheme F



Scheme K

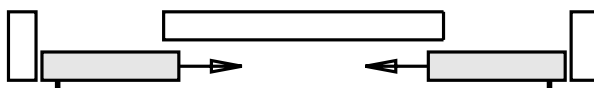

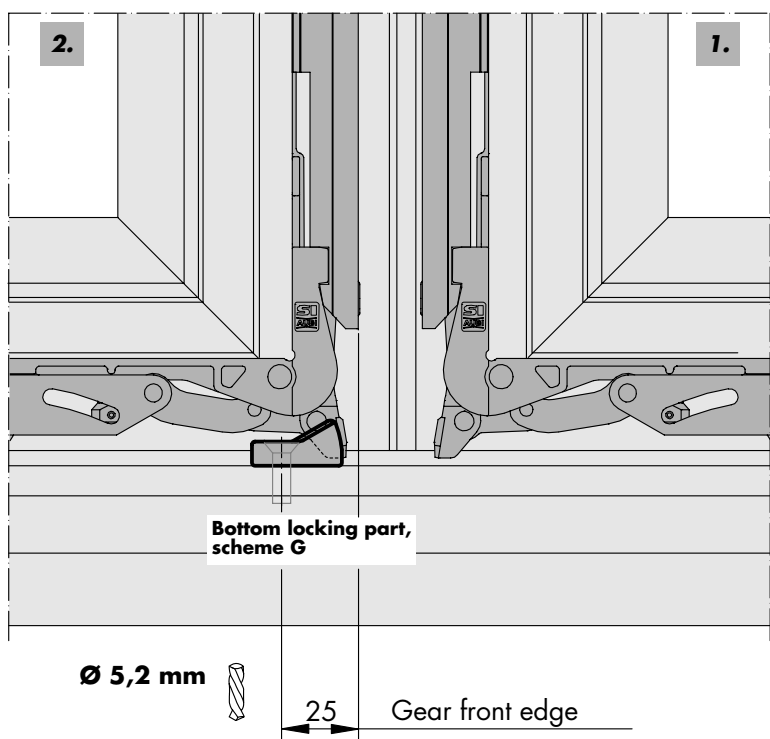
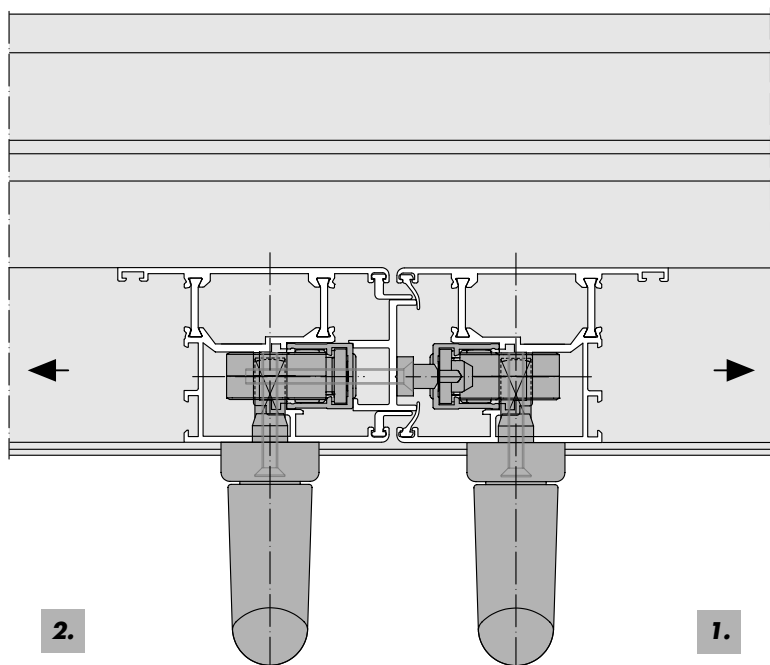

Notes for scheme C:

- The locking points are lowered by 4mm
Reduce Dim A to C on page 14
by 4 mm
- screw a self tapping screw B6,3 x 38 **(22)**
into the frame ~ 50 mm from the sash leading
edge above the slave sash
[see also page 9]
- To avoid misoperation of the two leaves ,
the master and slave sashes should be clearly
identified.

The sliding doors should only be operated
in the following sequence !

- Opening: first the master [1.],
then the slave sash [2.]
- Closing: first the slave sash [2.],
and then the master [1.]

Fitting the locking parts , bottom, Scheme G

- A Mark the running rail 25 mm behind the gear front
edge
and ctr punch for a csk screw M6 x 20 (21).
- B Pre drill with a Ø 5,2 mm drill.
- C Screw in the locking part for Scheme G, bottom**(20)**

HS-PORTAL 200 LM Hardware information Jigs

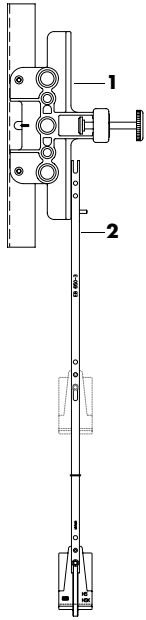

Materialshorttext	Tool	Materialnumber
<p>Jig EB 651-3 consisting of: <i>for gear drillings</i></p> <p>Pos. 1 Bohrlehre EB 651-3* <i>Jig has backset 51; According to profile dependent back- set please use distance piece on site</i></p> <p>Pos. 2 Adjusting rod (incl. lower stop) <i>for EB 650-3 and EB 651-3 Lower stop needs to be shortened by 12mm! See page 5 a. 6</i></p>	<p>Drill: \varnothing 12 mm \varnothing 20 mm</p>	<p>PABB0010-521010</p> <p>157244</p>
<p>Centre punch KF <i>for ctr punching the hole for the lock- ing part</i></p>		<p>141892</p>